



CH 05 - PRESTAZIONI CON MOTORI A 4 POLI 1400 GIRI ENTRATA

TIPO	i=ratio	n2 r/min	Kw=P1	Nm=T2	f.s.	Pred. attacco motore possibili	
CH 05	7	200	1.1*	40	1.4	80/71	B5/B14
	10	140	1.1*	49	1.2	80/71	B5/B14
	14	100	0.75	57	1.1	80/71	B5/B14
	18	78	0.55	52	1.1	80/71	B5/B14
	24	58	0.55	67	0.9	80/71	B5/B14
	28	50	0.55	73	1.0	80/71	B5/B14
	36	39	0.37	61	1.1	71	B5/B14
	45	31	0.37	65	0.9	71/63	B5/B14
	60	23	0.25	60	1.0	71/63	B5/B14
	70	20	0.22	55	0.9	63	B5/B14
	80	17	0.18	54	1.0	63	B5/B14
	100	14	0.18	50	0.9	63	B5/B14

* Motori gr. 80

Peso Kg 3

DIMENSIONI

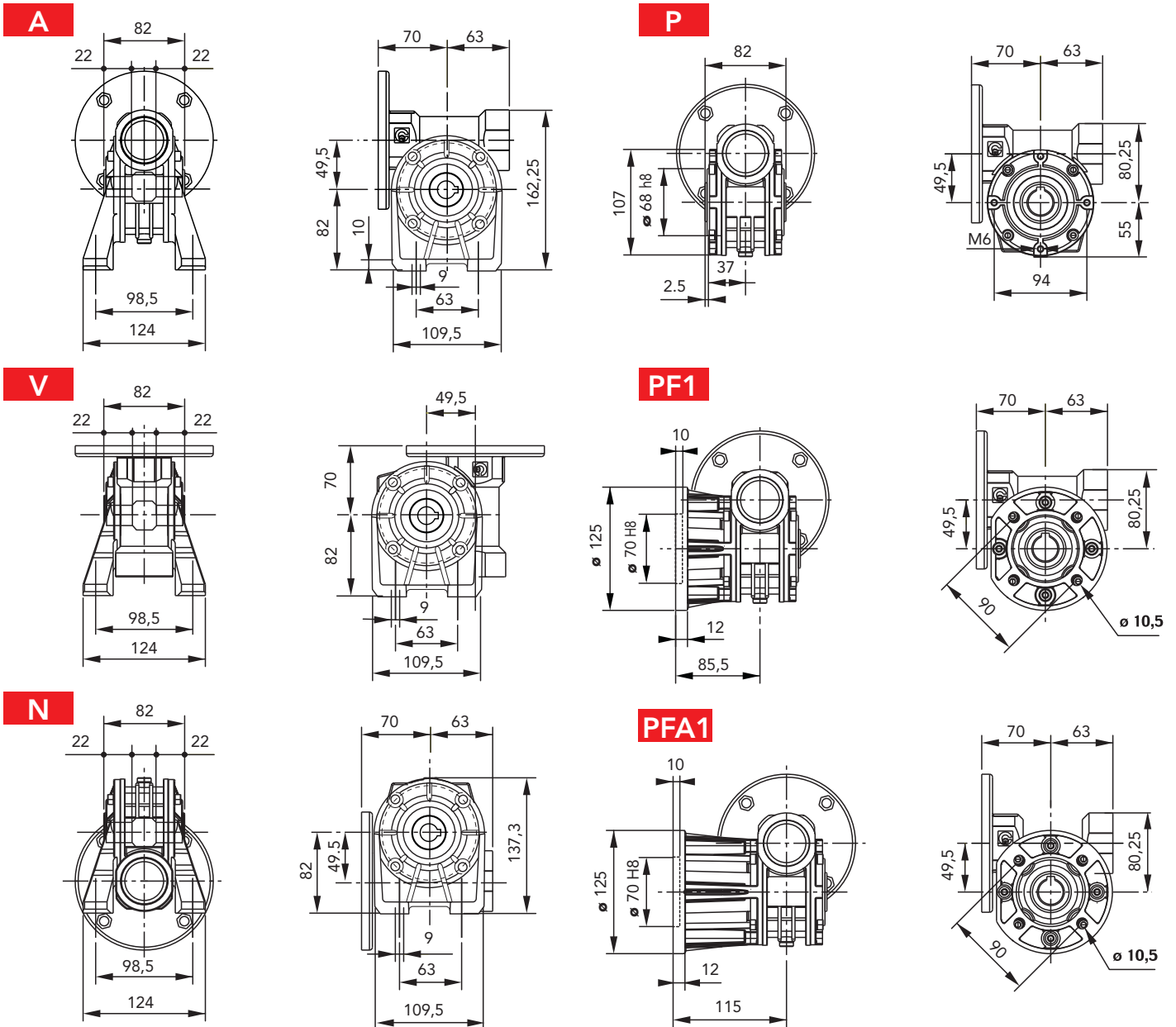



CH 03/04/05 POSIZIONE DI MONTAGGIO

B3

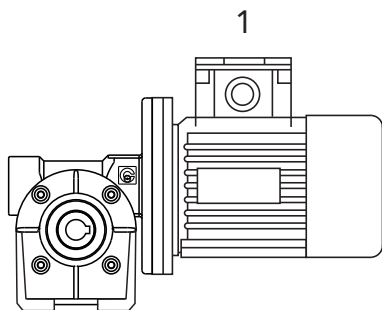

B6

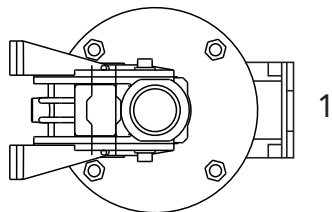

V5

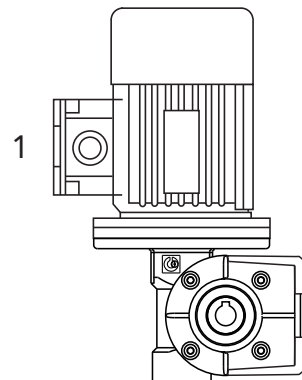

B7

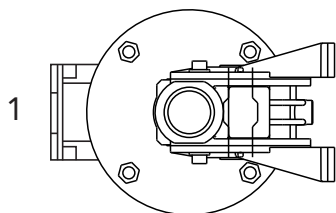

B8

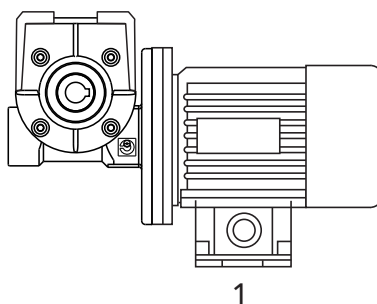

V6

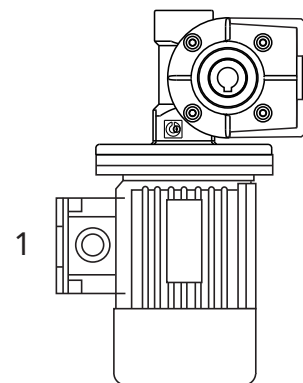

PF1

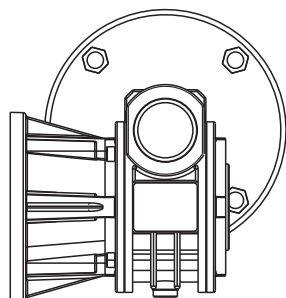

PF2

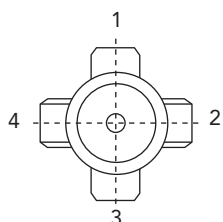
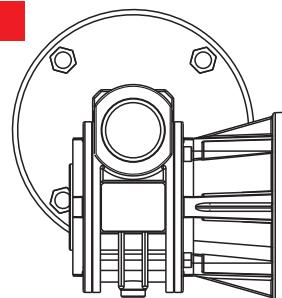

B3

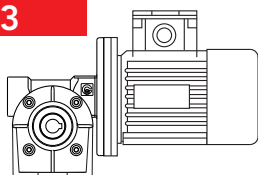

POSIZIONE MORSETTERIA

N.B. La posizione della morsetteria si riferisce sempre alla pos. B3